



**“An Amazing Adventure through two Patrimonial Cities: Rome & Seville”**

# SCALE MODELS

ISTITUTO GIUSEPPE MONTEZEMOLO  
Scuola Primaria e Secondaria di  
primo grado



## Scale Models activities in ICS Giuseppe Montezemolo (Rome, Italy) and IES Punta del Verde (Seville, Spain)

As part of the innovative educational activities included in the Erasmus+ project “An Amazing Adventure through two Patrimonial Cities: Rome & Seville”, the students of both schools, ICS Giuseppe Motezemolo and IES Punta del Verde, learnt how to design and implement scale models and created their own of the monuments seen during the mobilities to both cities.

In ICS Montezemolo, it was organized a course for the students to learn this technique. This course, which included the construction of the models, was shared with the Spanish students when they visited Rome in the last mobility. Here it is presented the content of the course together with photographs of the students working together and of the final scale models.

In IES Punta del Verde, the students created their designs in the Art class with their art teacher Nelly Oliveras with two different programs: Tinkercad and Freecad. Later it was bought a 3D printer to have the scale models built. It will be used in the future to make similar activities in the school.

The results of this activity will be permanently displayed in both schools.

# 3D modeling activity

Within the Erasmus Project 2017--2019

I.E.S. Punta del Verde, Seville

**I.C. Montezemolo, Rome**

I.I.S. Via delle Sette Chiese, Rome

# Students and their attendance

	11/12/18	19/12/18	8/01/19	16/01/19	24/01/19
Galluzzi Sara	P	P	P	P	A
Ghisio Erba Lorenzo	P	P	P	P	P
Carnicelli Francesco	P	P	P	P	P
Di Noia Simona	P	P	P	P	P
Cafora Salvatore	P	P	P	P	P
Renzi Giada	P	P	P	P	P
Russo Giulia	P	P	P	P	P
Stromsather Anna	P	P	P	P	A
Petrucelli Milena	P	P	P	A	A
Venanzi Vittoria	P	P	P	P	P
Castello Petra	P	P	A	P	P
Pandimiglio Lucia	P	P	A	P	P
D'Angelo Simone	P	P	A	P	P
Ruggiero Alessandro	P	P	A	P	P

# Students and their attendance

Student	Presences/Tot (%)
Galluzzi Sara	80%
Ghisio Lorenzo	100%
Carnicelli Francesco	100%
Di Noia Simona	100%
Cafora Salvatore	100%
Renzi Giada	100%
Russo Giulia	100%
Stromsather Anna	80%
Petrucci Milena	60%
Venanzi Vittoria	100%
Castello Petra	80%
Pandimiglio Lucia	80%
D'Angelo Simone	80%
Ruggiero Alessandro	80%

# Partnership: Climax

Association involved in scientific and technological divulgation



Among other activities,  
they offer **3D modeling**  
**courses and 3D printer use**



# Edmodo “classroom”

Where:

- Sharing materials and ideas
- Comparing procedures
- Asking and answering questions

The image shows a screenshot of the Edmodo web application interface. The browser is Firefox, and the URL is <https://new.edmodo.com/groups/erasmus-romarte-28915663>. The page displays the profile of the teacher, Ivan Prado Longhi, and the class name, Erasmus RomArte, with 14 students involved. The interface includes a navigation bar with options like Home, Da fare, Registro, Biblioteca, Messaggi, and Notifiche. A central message box is visible, along with a sidebar showing class details and a list of posts. One post features a 3D model of the Colosseum and a discussion about a project.

**Students...**

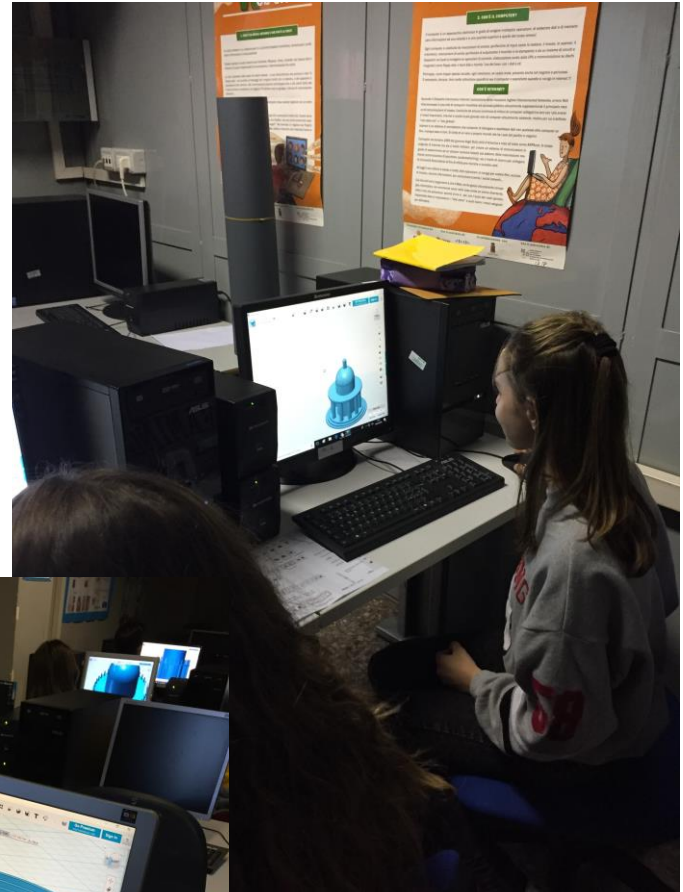
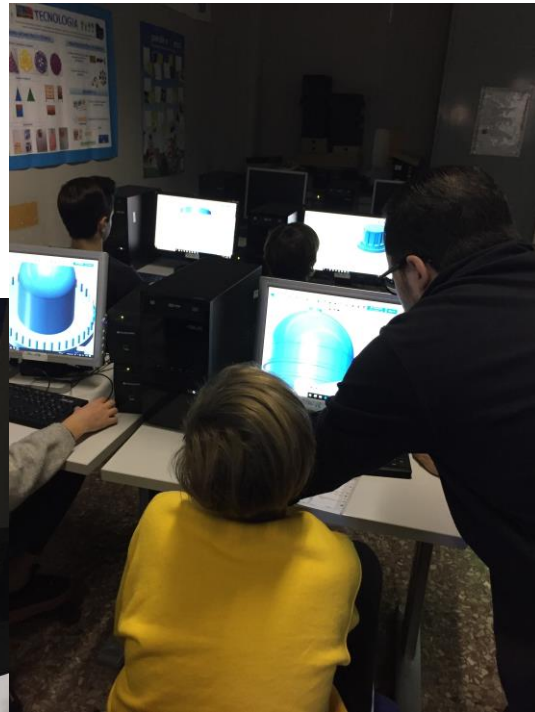

**...at...**

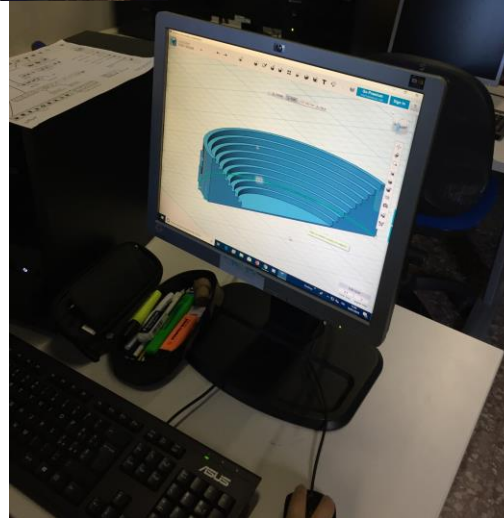

**...work...**



# Pantheon

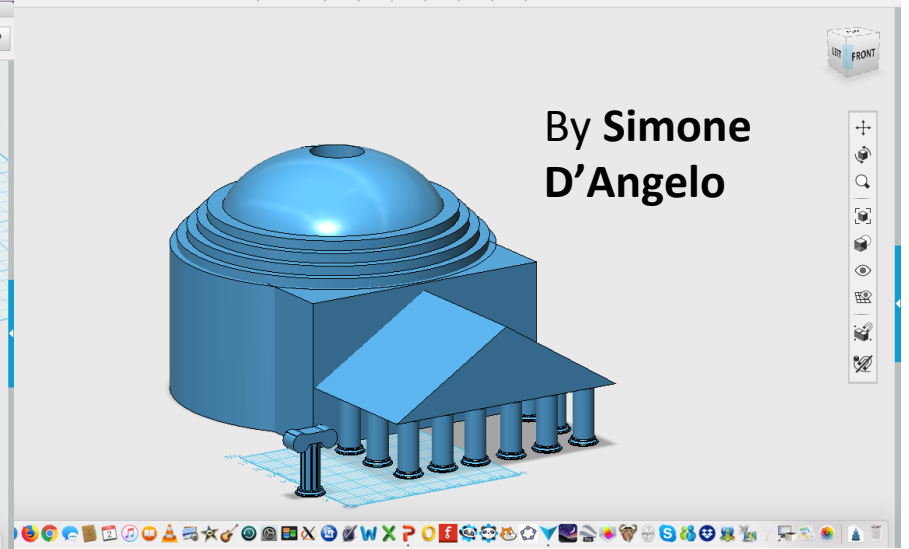
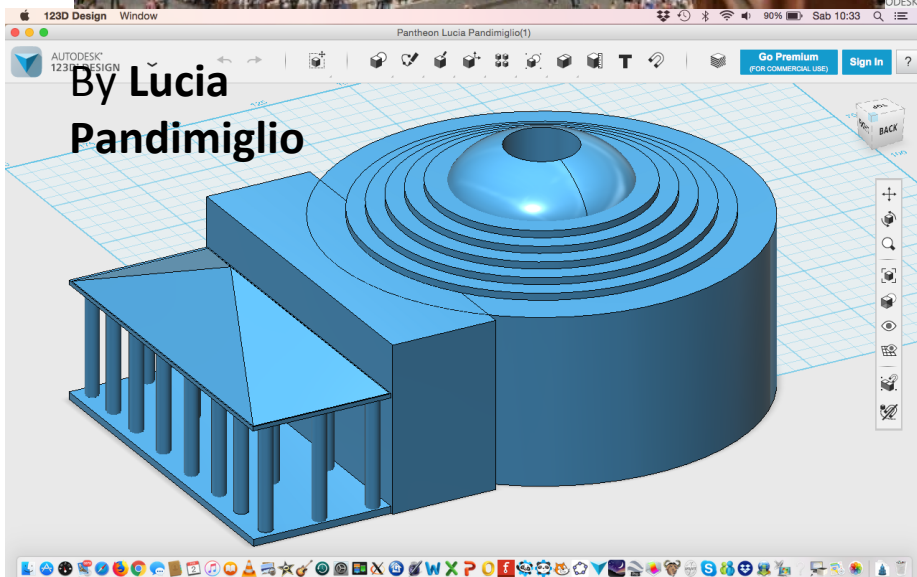
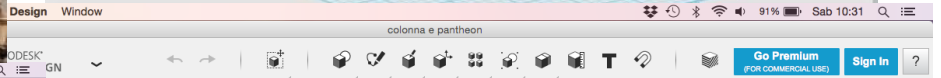
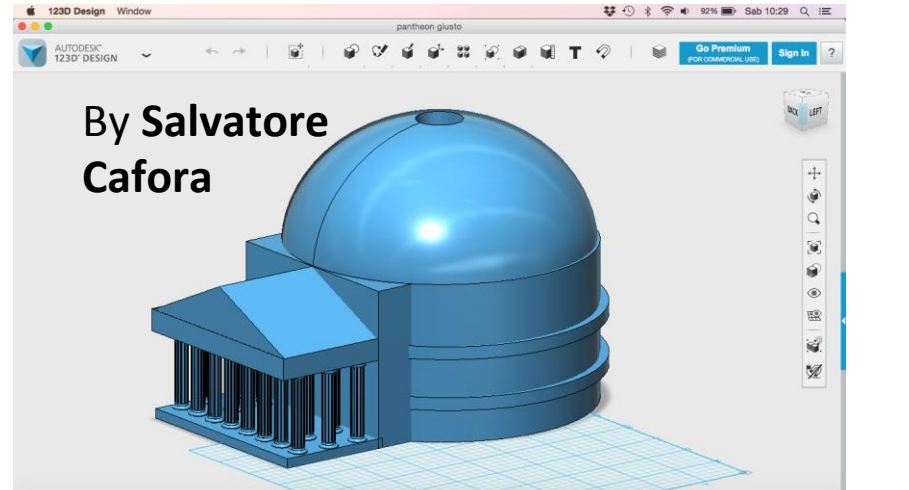

# Tempio di Ercole Vincitore (or “di Vesta”)

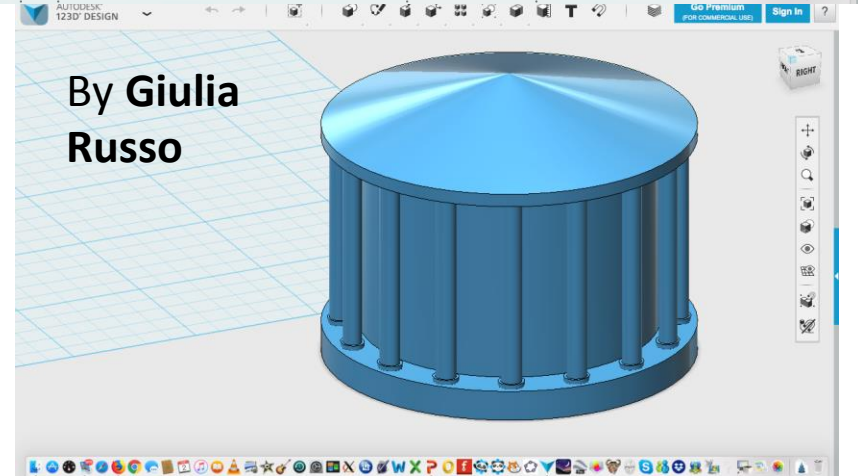
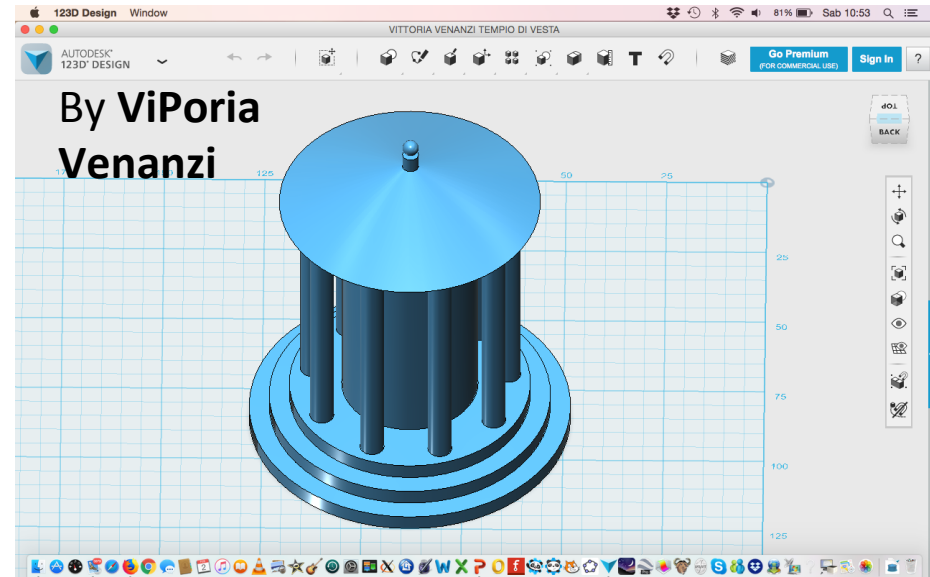
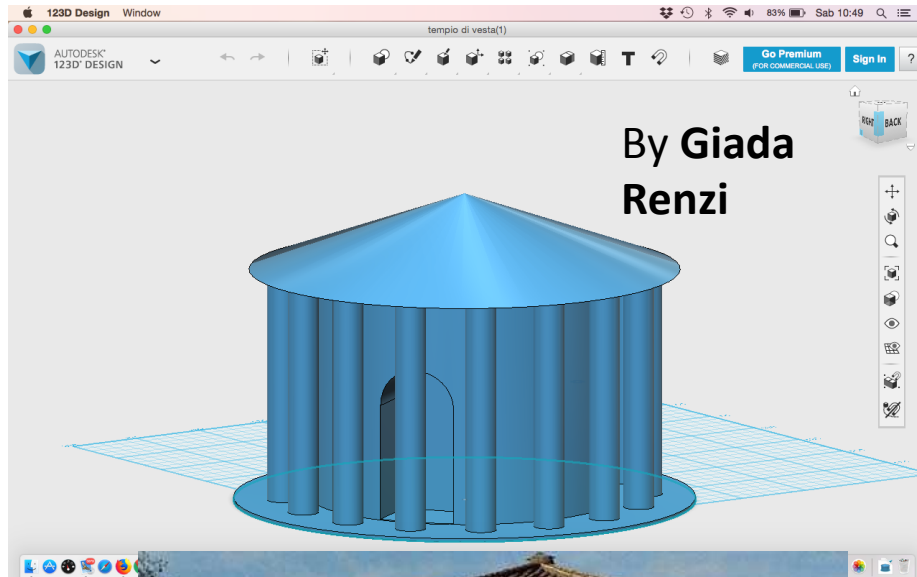

# Tempietto di S. Pietro in Montorio

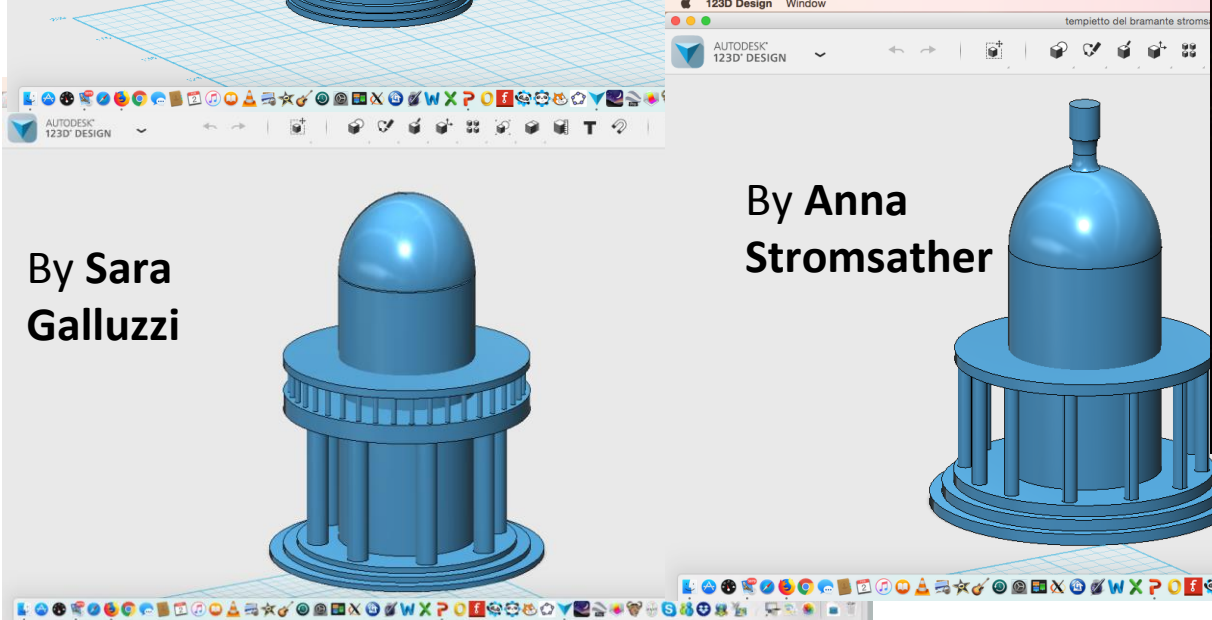
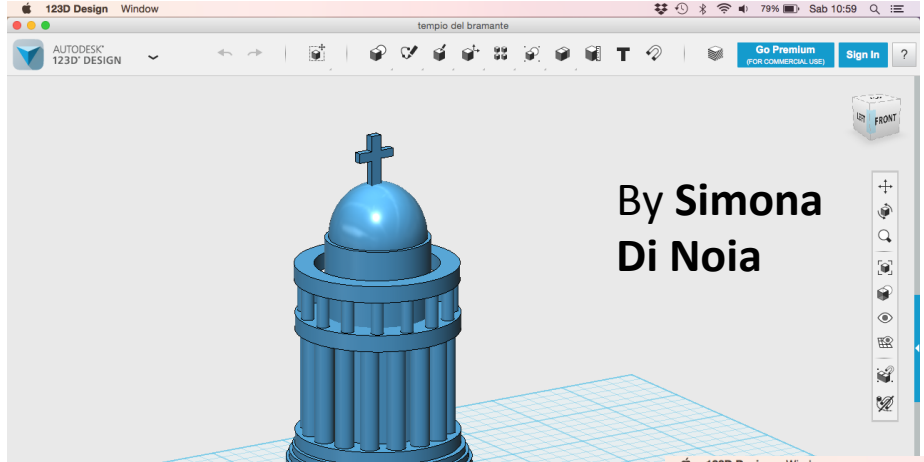

# Teatro di Ostia Antica

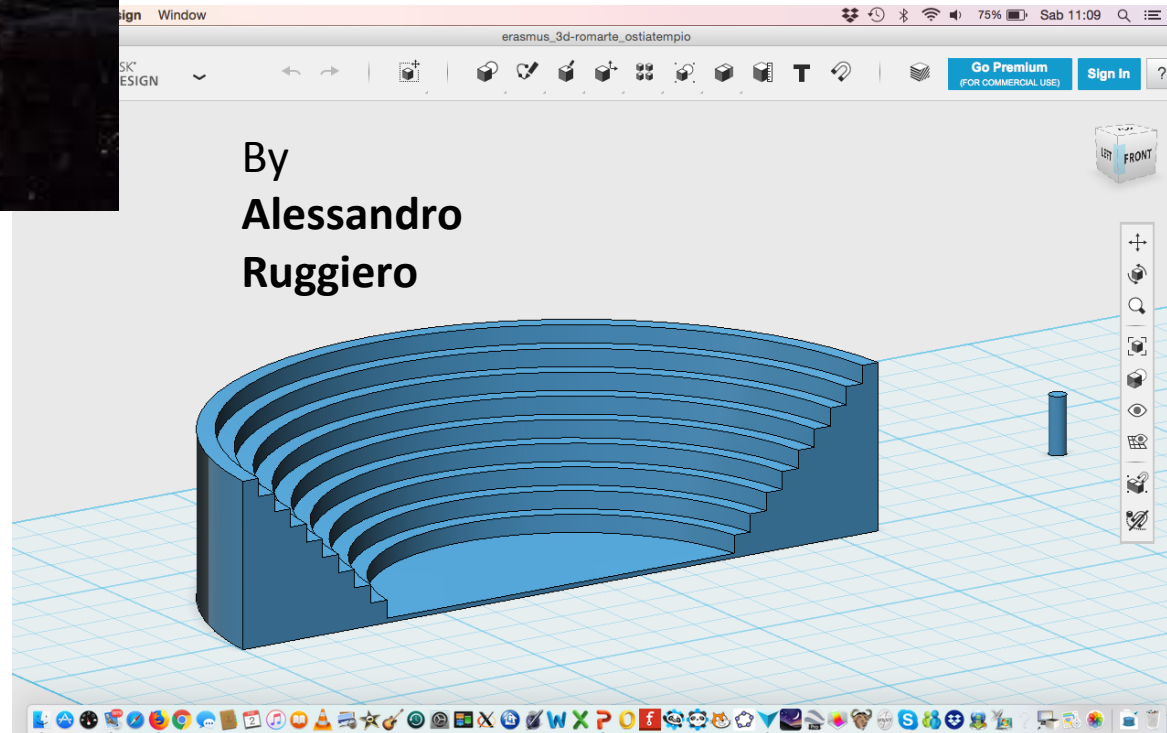

# A difficult task: Colosseum

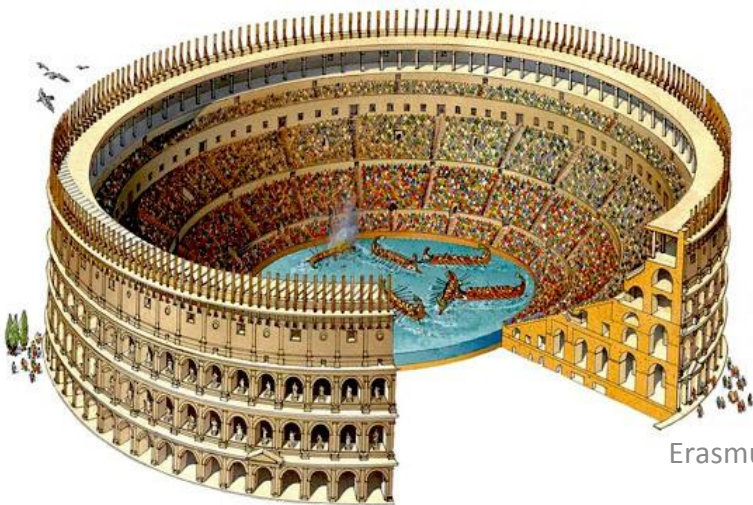
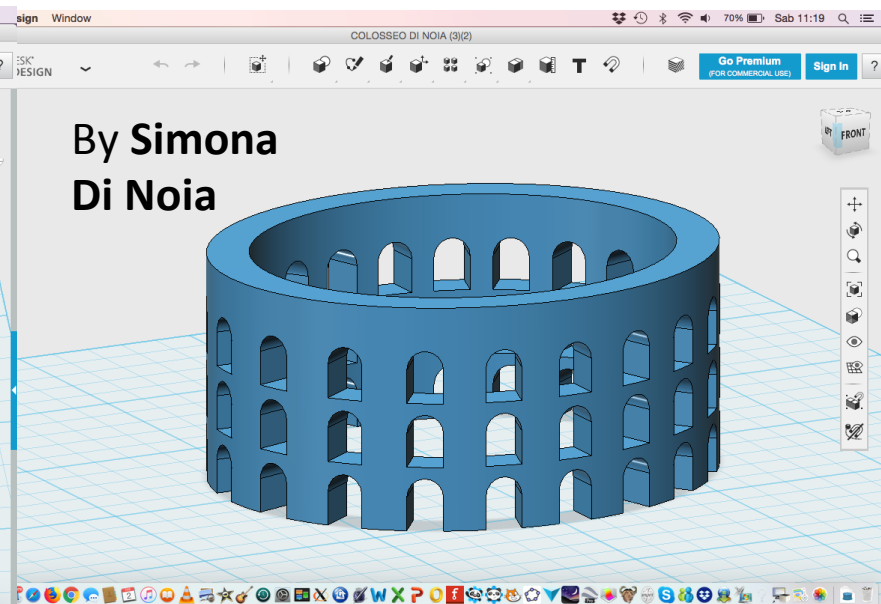
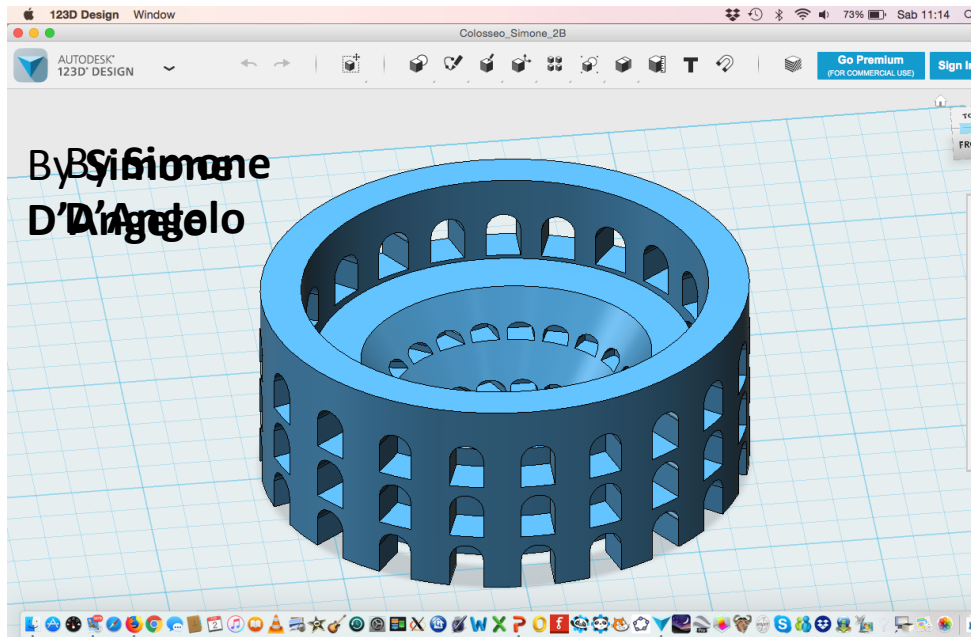

# Work in progress...

... for a more realistic representation of the Colosseum, both in its original and today appearance

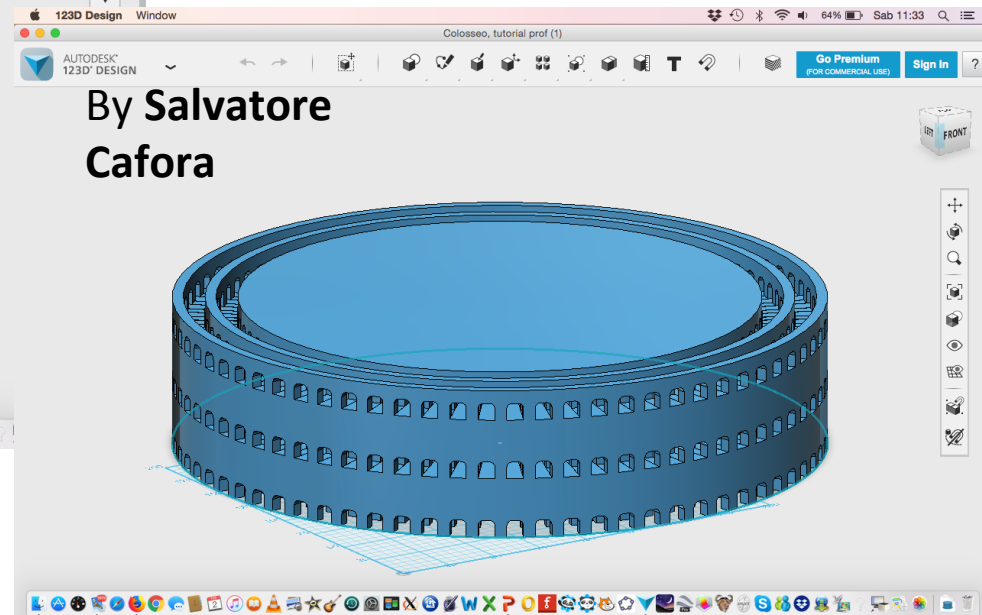
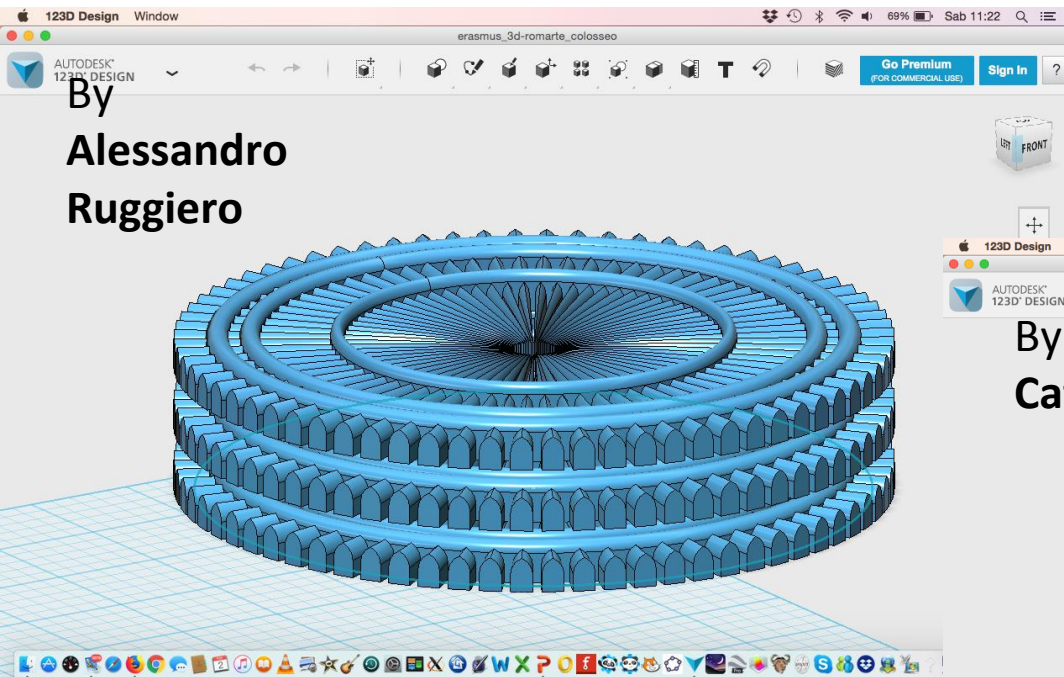

# More works...

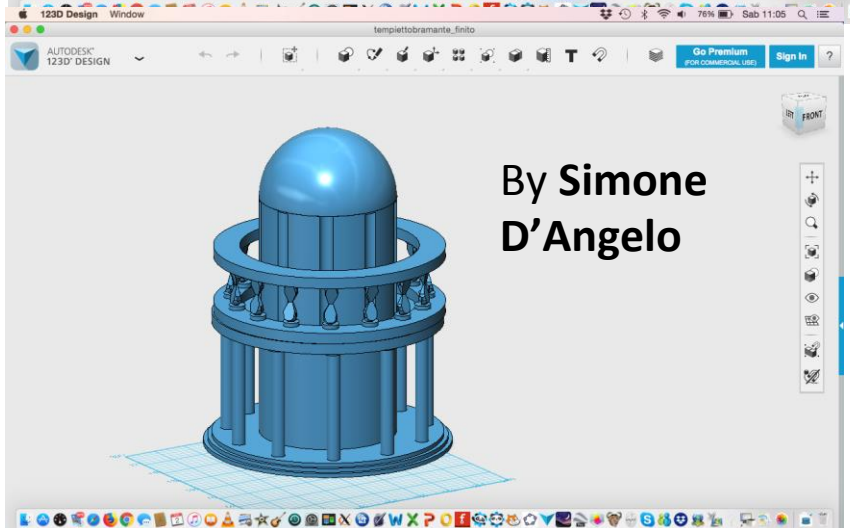
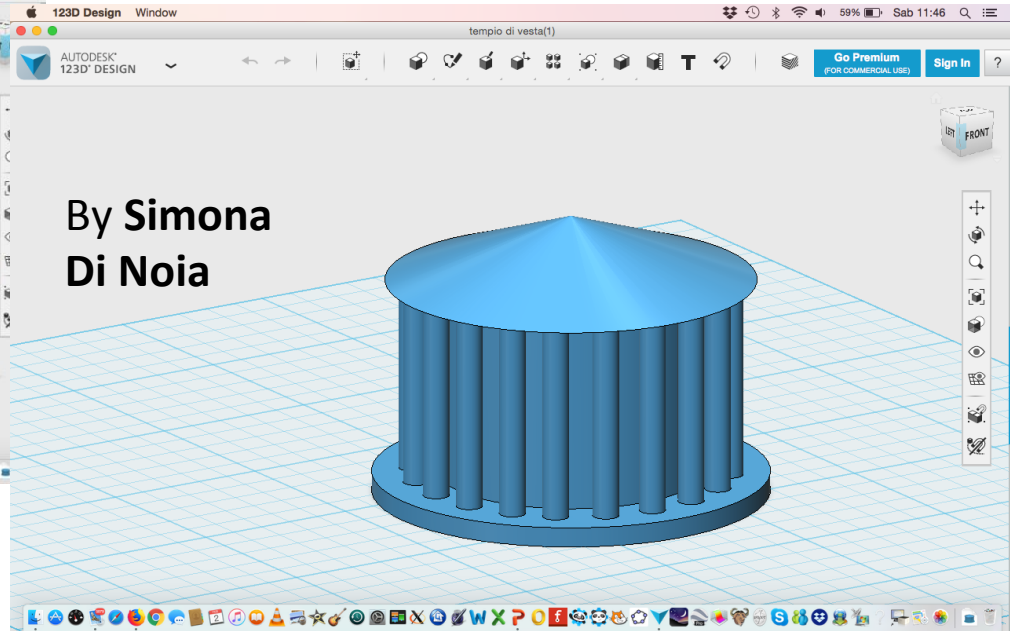
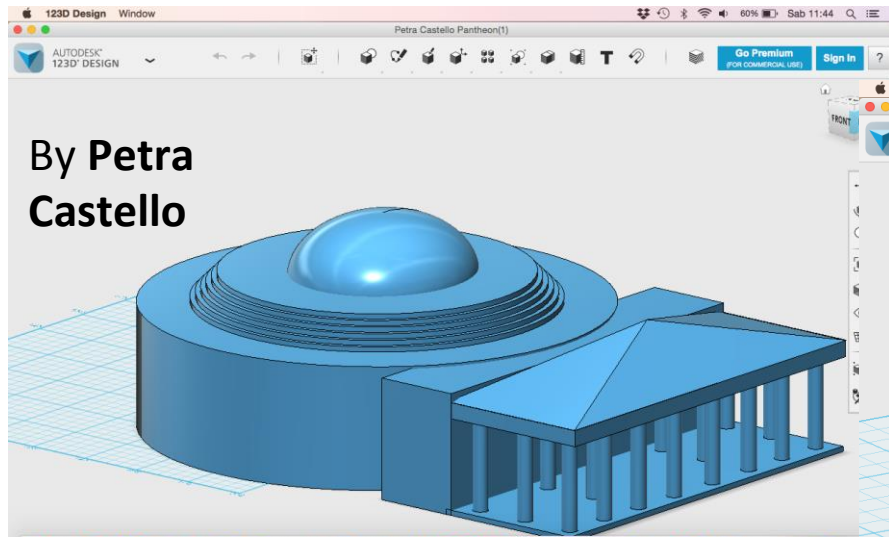

# Missing: Baroque

Baroque buildings are very difficult to realize with the software we are working with (“strange”, irregular shapes and too many statues!)

Probably we will focus on **S.Andrea al Quirinale** by **G.L. Bernini**





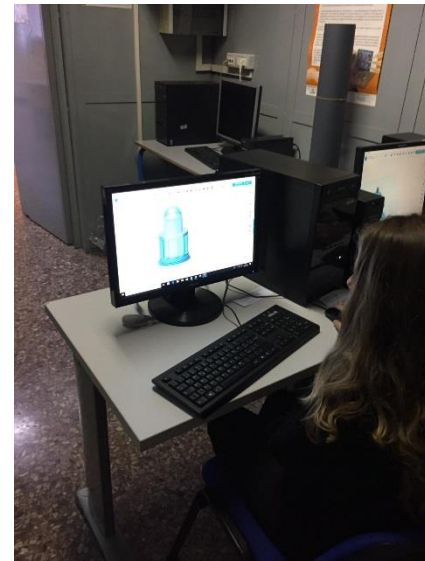
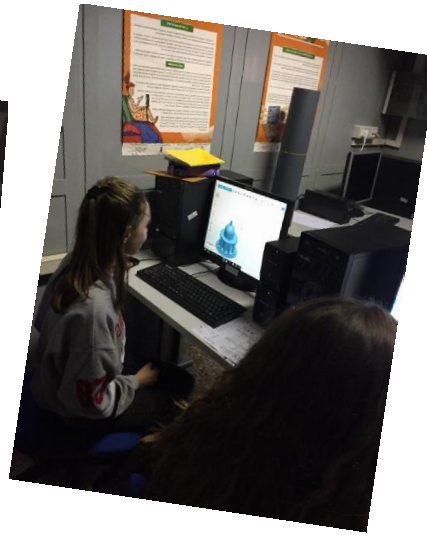
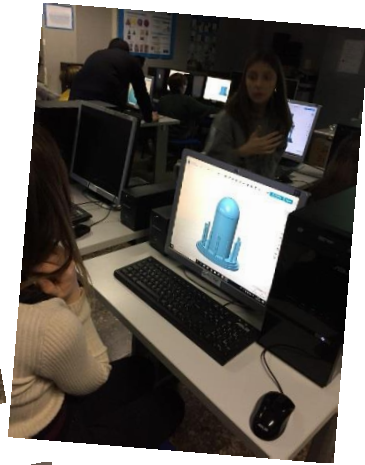
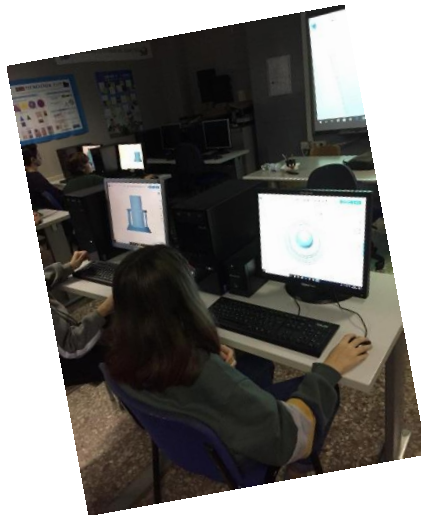

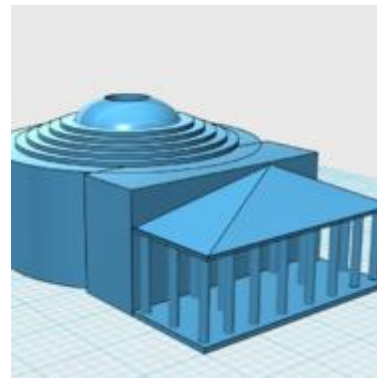
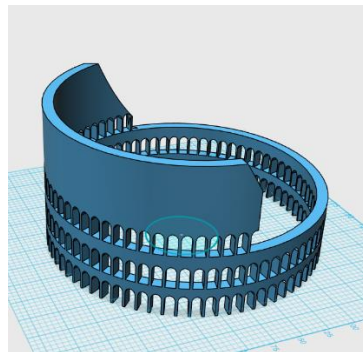
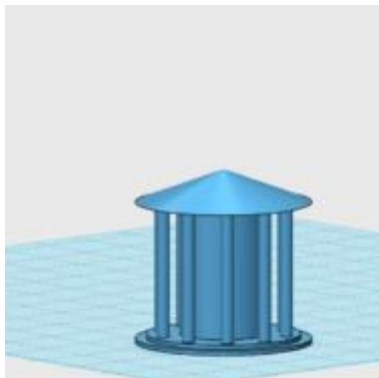
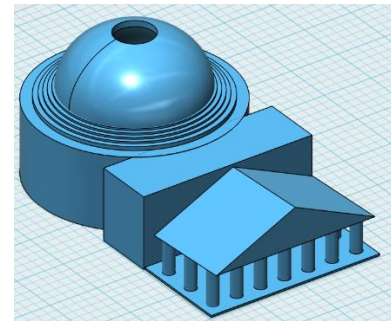
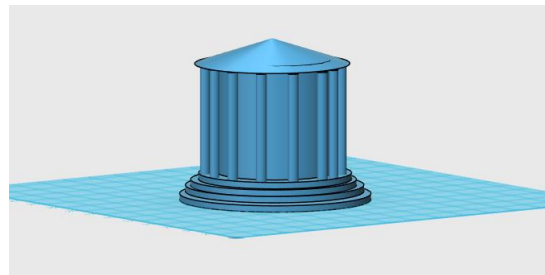
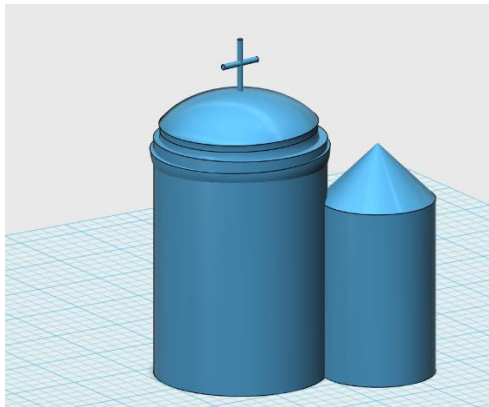
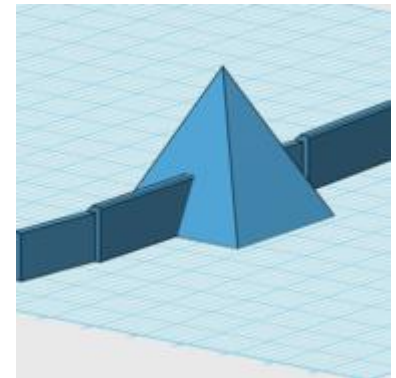
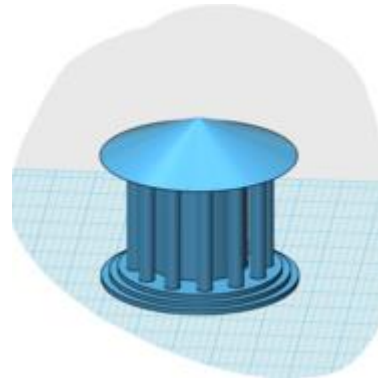
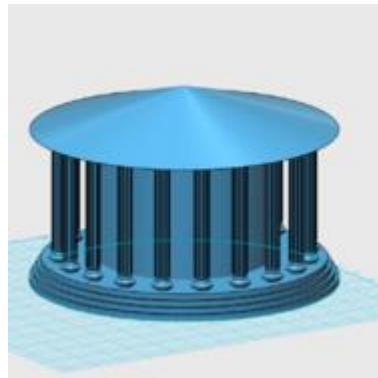
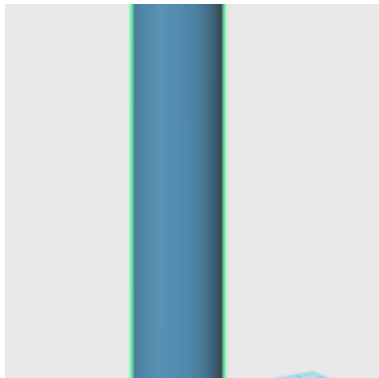

# Sharing the course with Spanish students

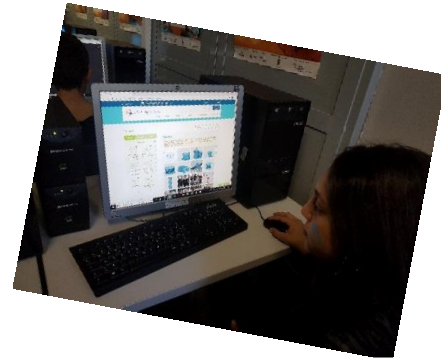
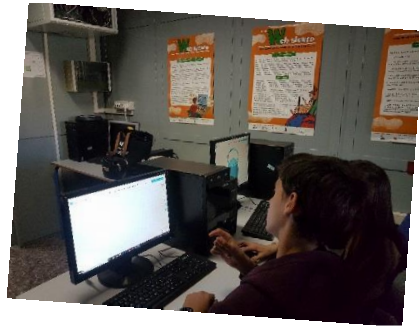

# Final results in Rome



# Scale Modeling in IES Punta del Verde: Tinkercad and Freecad

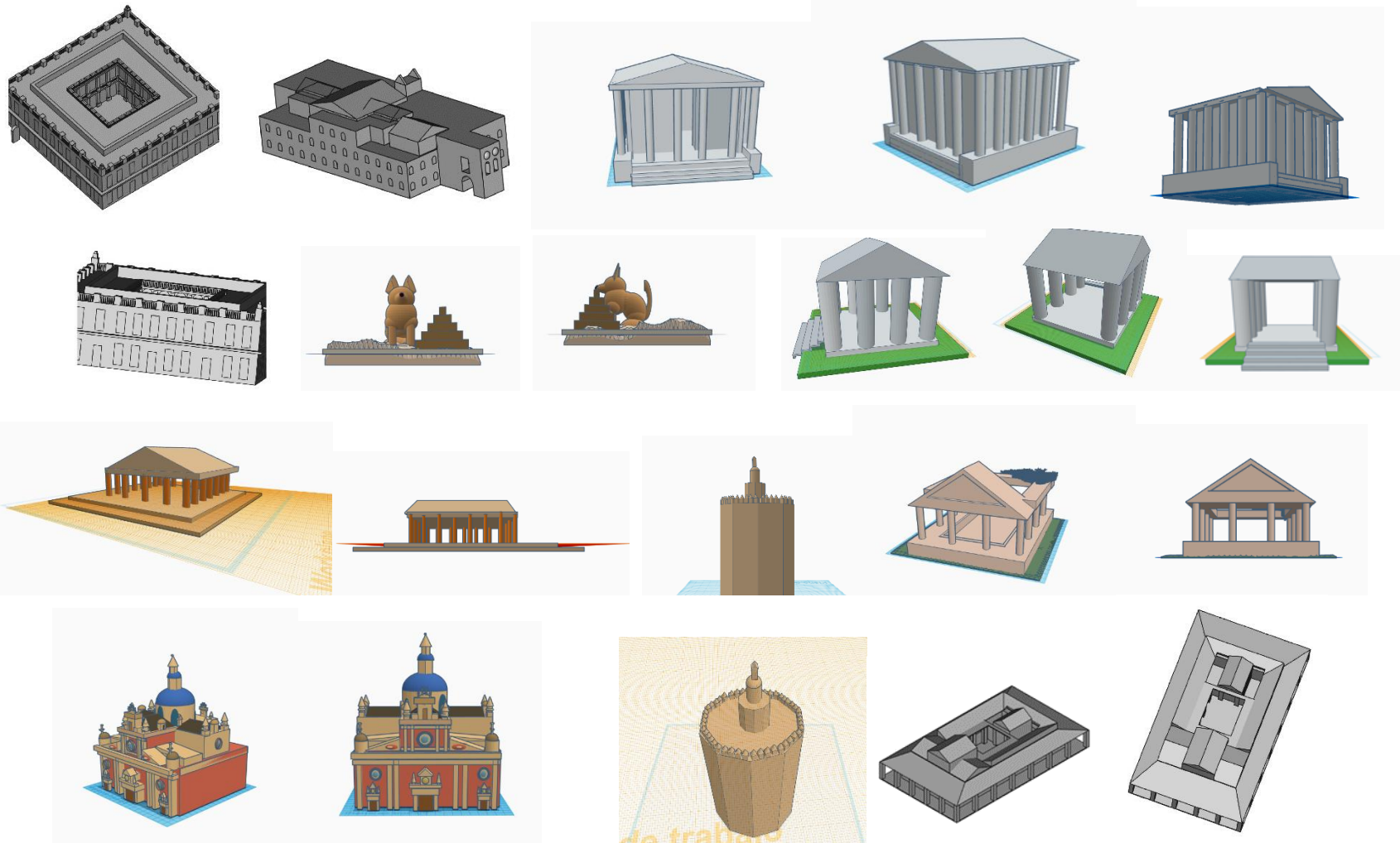

# BAELO CLAUDIA



# 3d model temple recreation



# Salvador church Seville



# Leopoldo de Figueroa XVII c



3 D models



## Birds house, Italica, Seville II century ac



3D model





# Traianeum. Italice. Seville.II Century a.c.

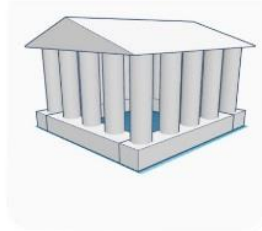

3D  
Model

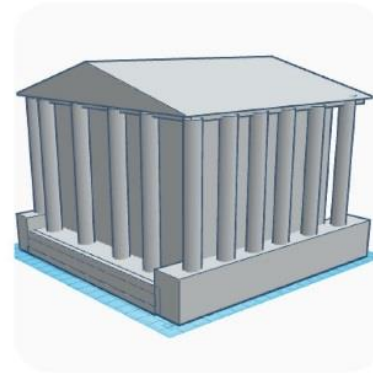

# Giralda tower. Sevilla XII-XVII Century

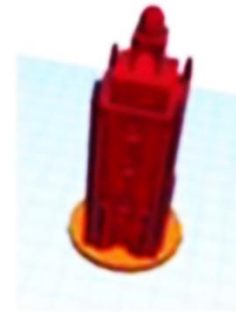
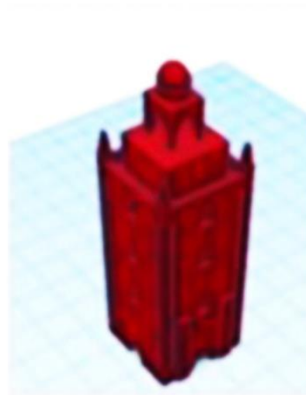

3D models

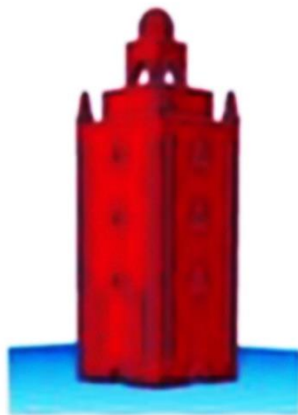

Co-funded by the  
Erasmus+ Programme  
of the European Union

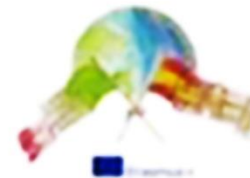

# Italica amphitheatre. Seville. II Century a.c.



## 3D models

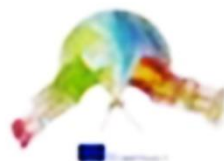

# Marmoles street temple. Seville. Roman period

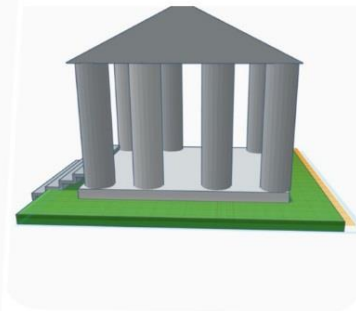
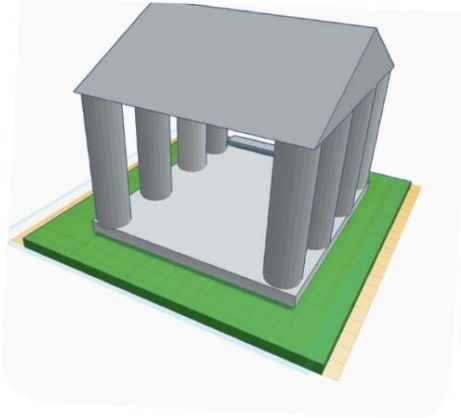

## 3D models

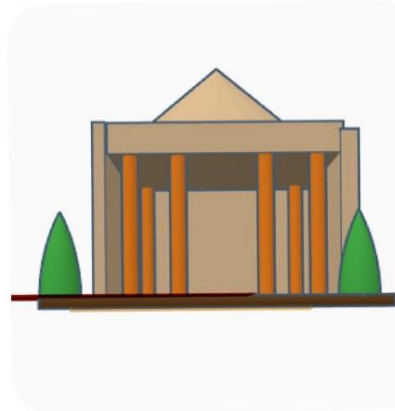
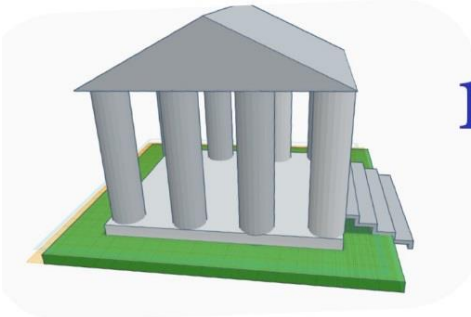

Seville town hall XV-XVIII c.

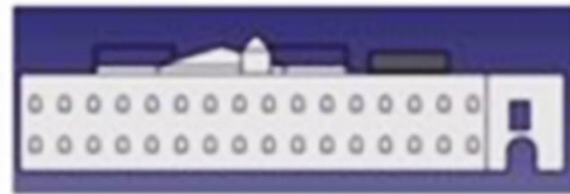
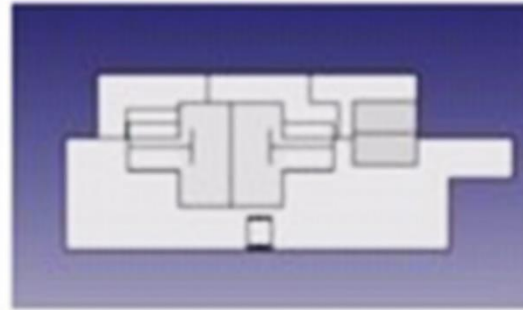
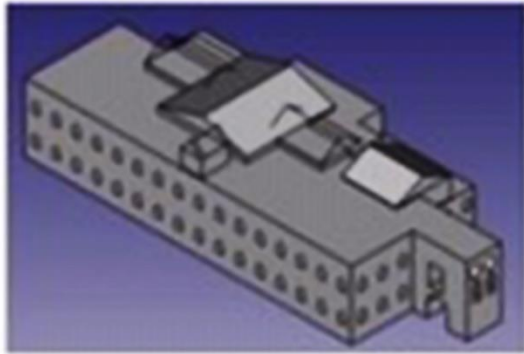

# BIRDS HOUSE IIC a.c.



3D models

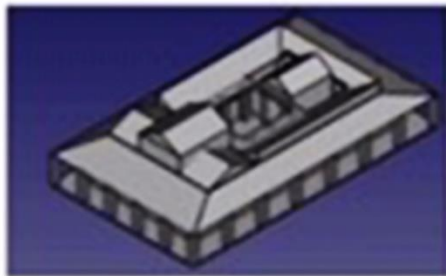

# Archive of the Indies

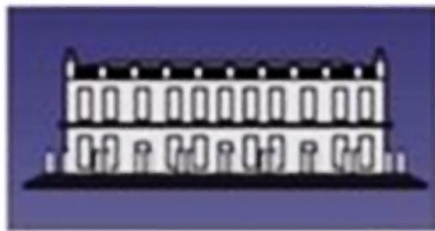
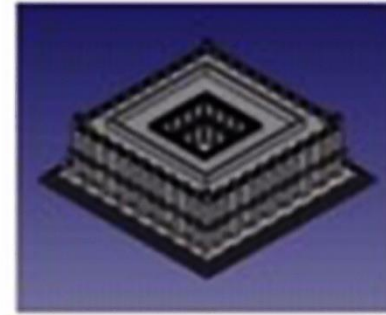
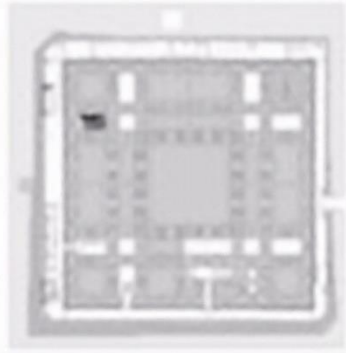

3d models



# SCALE MODELS





# Italica amphitheatre. Seville.II Century a.c.

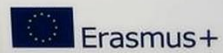
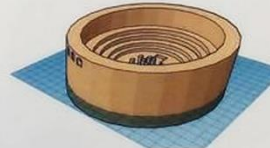
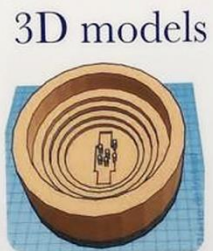

# BAELO CLAUDIA



## 3d model temple recreation

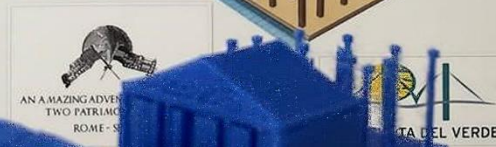
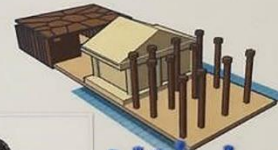
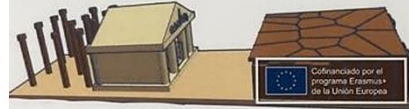
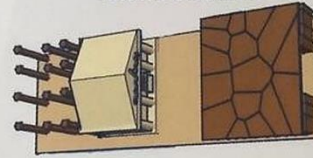

Marmoles street temple. Seville.  
Roman period

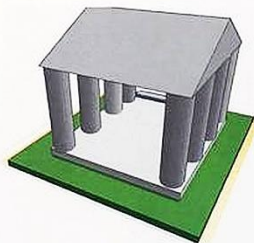

3D  
models



Co-funded by the  
Erasmus+ Programme  
of the European Union



Birds house. Italica, Seville II century ac

3D model

Salvador church Seville Leopoldo de Figueroa XVII c

3 D models

BAELO CLAUDIA 3d model temple recreation

Traianeum. Italica, Seville. II Century a.c.

3D Model

Italica amphitheatre. Seville. II Century a.c.

3D models

Marmoles street temple. Seville. Roman period

3D models



**Ref. Project: 2017-1-ES01-KA219-038201\_1**

**DISCLAIMER**

**“The European Commission support for the production of this publication does not constitute an endorsement of the contents which reflects the view only of the authors, and the Commission cannot be held responsible for any use which may be made of the information contained therein.”**



Co-funded by the  
Erasmus+ Programme  
of the European Union